



TILLOTSON LTD., CLASH INDUSTRIAL ESTATE,
TRALEE, CO. KERRY, IRELAND

PHONE: +353 66 7121911 FAX: +353 66 7124503

e-mail: sales@tillotson.ie



SERVICE MANUAL

INTRODUCTION

To keep pace of new market demands Tillotson has designed and developed a new miniature all-position diaphragm carburetor, the HU series. This versatile unit is lightweight and compact, only a 1-1/8" cube, but it still comprises a self-contained fuel pump and filtering screen

HU SCHEMATIC

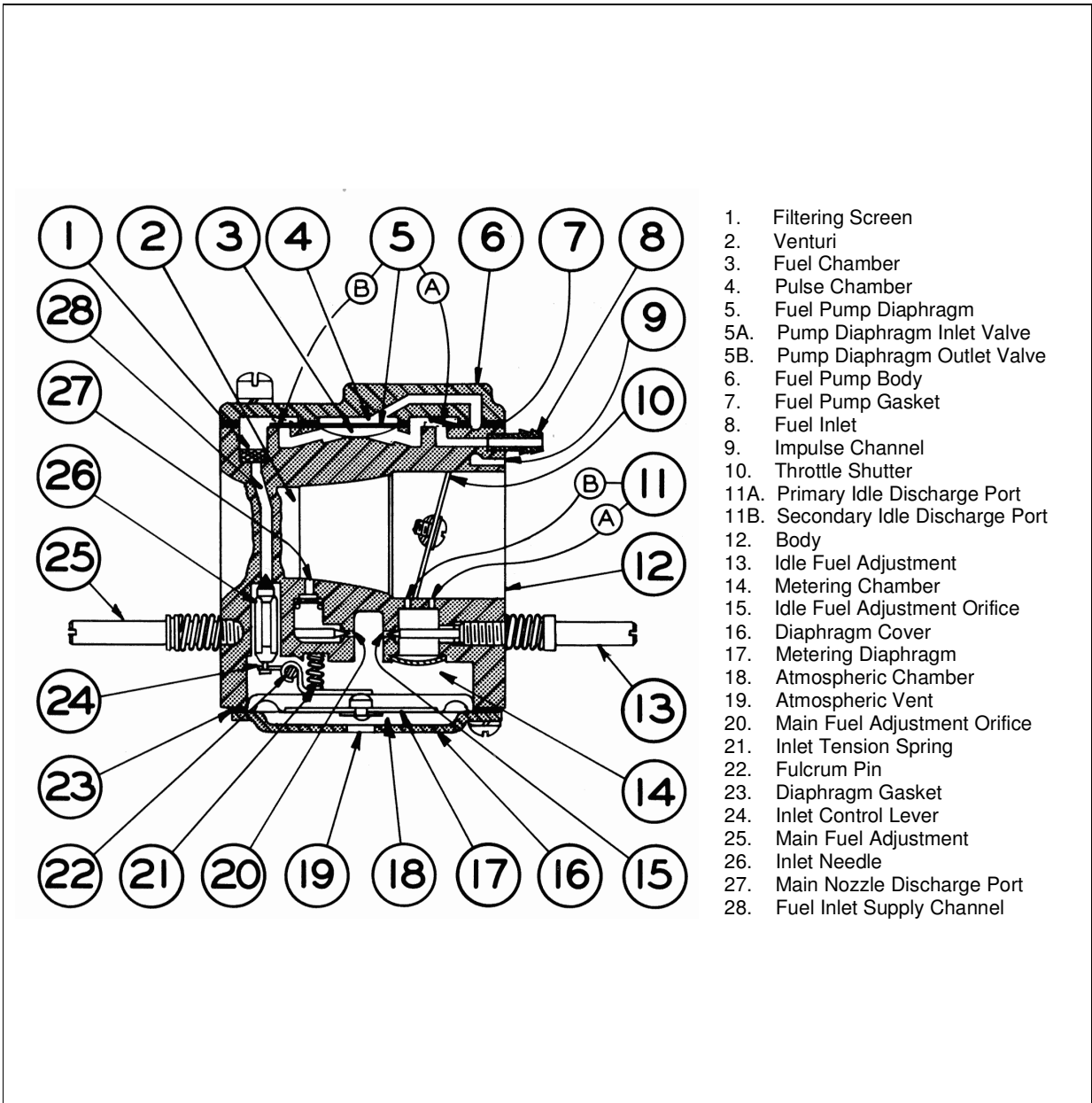

CONSTRUCTION DATA

The HU series carburetor is die-cast aluminium, consisting of three basic parts: metering body, pump cover plate and main diaphragm cover plate. This carburetor incorporates many of the components found in float type carburetors: throttle, idle and high speed mixture screws, idle speed screw and inlet needle.

High speed and idle mixture screws are spring friction type and require no packing. These mixture screws are located on the right side looking toward air horn.

A rubber tipped needle seats directly on a machined orifice in the body casting. An inlet tension spring exerts a pre-determined force on the inlet control lever, which holds the needle on its seat.

A metering diaphragm is subjected to engine suction on the metering chamber side and atmospheric pressure on the vented side. Atmospheric pressure on the vented side pushes the diaphragm toward the inlet control lever, opening the inlet needle to allow fuel to enter the metering chamber, from which it is then delivered into the mixing passages.

The inlet control lever hooks on the inlet needle on some models and a self-tapping screw holds the fulcrum pin in place.

Movement of the pump diaphragm is caused by pulsations from the engine, acting on it through an impulse channel. This movement draws fuel into the fuel chamber and a reverse movement forces fuel out of the fuel chamber through the inlet needle into the metering chamber.

An easily accessible fine mesh-filtering screen is located under the fuel pump cover and diaphragm.

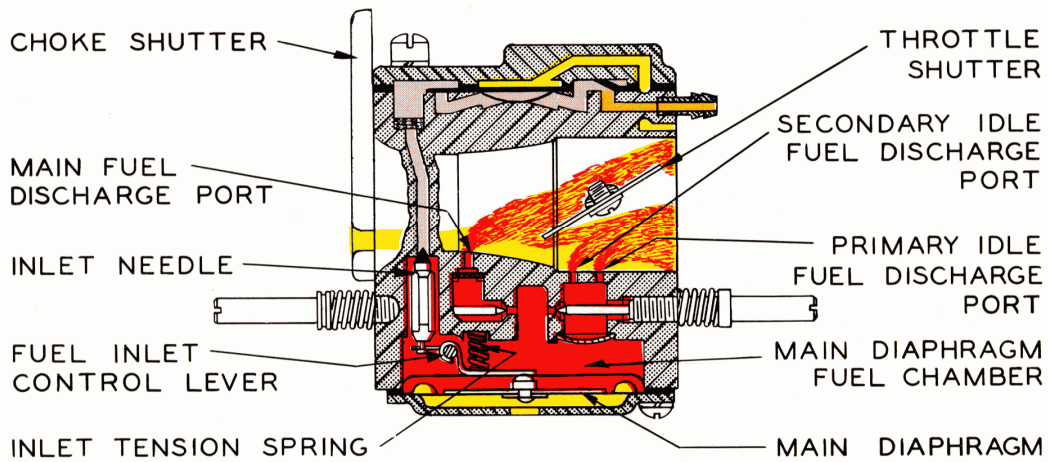

STARTING CHOKE OPERATION

Starting an engine with the "HU" Carburetor involves the same methods that are used in a conventional float feed carburetor

When starting a cold engine, place the shutter blade in the closed position and throttle shutter in a cracked or open position. As the engine is cranked, engine suction will be transmitted to the diaphragm fuel chamber through both primary and secondary idle discharge ports as well as the main fuel discharge port, creating a low-pressure area on the fuel side of the main diaphragm. Atmospheric air pressure on the opposite side will force the main diaphragm upward causing the diaphragm button to depress the inlet control lever, overcoming inlet tension spring pressure, permitting fuel to enter through the inlet seat, then into the fuel chamber side of main diaphragm, up through the idle and high speed fuel supply orifices and channels, and out the discharge ports to the engine.

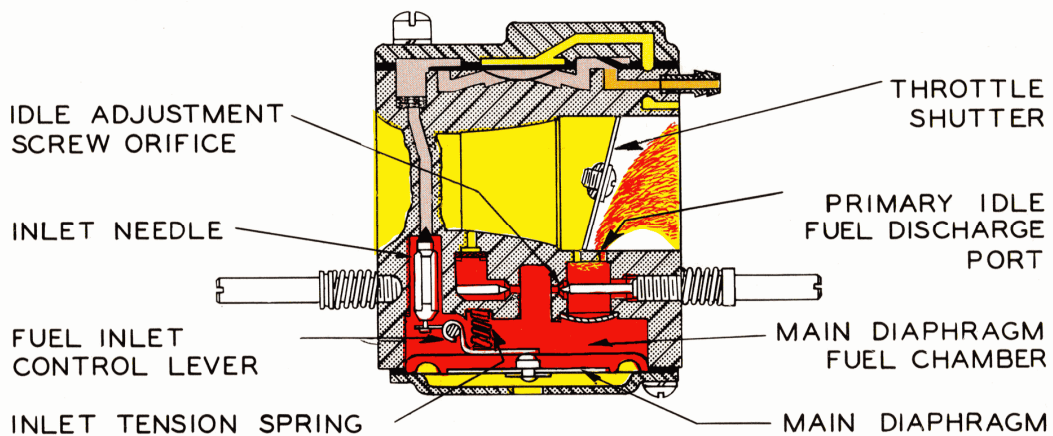

IDLING OPERATION

When engine is idling, throttle shutter is partially cracked. Engine suction is transmitted through the primary idle fuel discharge port to the fuel chamber side of main diaphragm via the idle fuel supply channel. Again, the main diaphragm is forced upward by atmospheric pressure, depressing the inlet control lever overcoming inlet tension spring pressure and permitting fuel to enter through inlet seat, and filling the fuel chamber. Fuel is then drawn up through idle mixture screw orifice and delivered to the engine through primary idle discharge port.

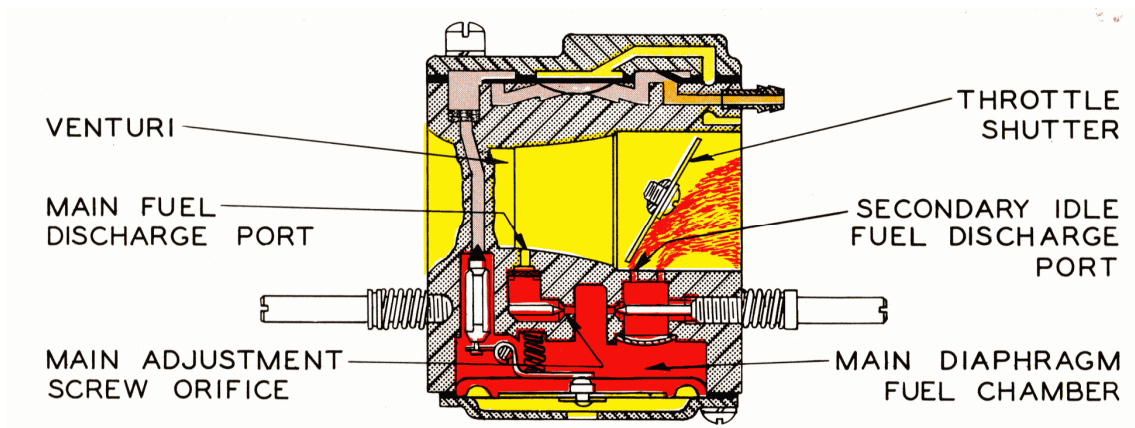

INTERMEDIATE OPERATION

Fuel is delivered into and through the carburetor in the same manner as when the engine is idling. However, as the throttle opens and engine speed increases, more fuel is supplied to the engine by valving in the secondary idle discharge port located immediately behind the throttle shutter.

As the throttle shutter continues to open and engine speed increases, the velocity of air through the venturi creates a low-pressure area at the venturi throat and diminishes the suction on engine side of the throttle shutter. When the pressure at the venturi throat is less than existing within main diaphragm fuel chamber, fuel is drawn up through high speed mixture orifice and out main fuel discharge port into air stream entering engine intake.

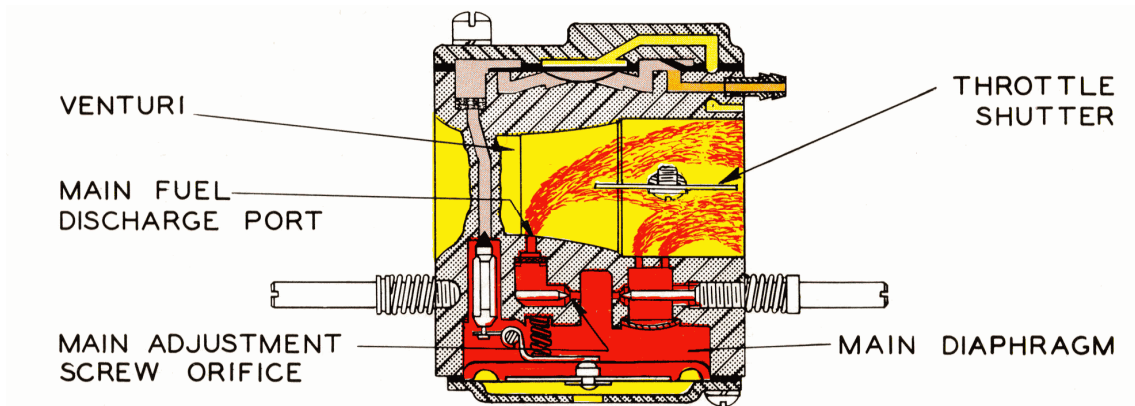

HIGH SPEED OPERATION

As the throttle shutter progressively opens from intermediate position to full open position, the air velocity through the venturi increases and fuel is metered up through high speed mixture orifice and main fuel discharge port in accordance with the power requirements of the engine. The action of the main diaphragm is the same as previously described with suction required to operate the diaphragm being transmitted through the main fuel discharge port.



SUPPLY FUEL



ATMOSPHERIC AIR



FUEL UNDER PRESSURE

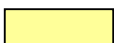

PUMP IMPULSE AIR



FUEL UNDER VACUUM

HOW TO DISASSEMBLE FOR CLEANING AND REPAIR

Before disassembling carburetor it is imperative to flush it clean of sawdust and dirt by pouring gasoline over it and tools.

1. Remove pump diaphragm cover screws and cover.
2. Remove pump gasket and pump diaphragm.
3. Remove filtering screen.
4. Remove main diaphragm cover screws and cover.
5. Remove main diaphragm and gasket.
6. Remove fulcrum pin screw, pin, control lever and spring.

7. Remove inlet needle

8. Remove idle and high speed mixture screws and springs.

Commercial carburetor cleaner can be used on all parts except diaphragms and gaskets. Before reassembling, rinse all parts in clean gasoline and blow off with compressed air. Do not use cloth, as tiny particles of lint adhering to carburetor parts will cause malfunction. Channels in the metering body can be cleaned by blowing through idle and high-speed mixture screw orifices. Do not use wires or drills to clean orifices.

ADJUSTMENT INSTRUCTIONS

OPEN HIGH SPEED MIXTURE SCREW AND IDLE MIXTURE SCREW ONE (1) TURN.

SERVICE HINTS

Be certain both diaphragms are installed correctly – the pump diaphragm next to the metering body, then the gasket – the main diaphragm gasket, then the main diaphragm. Evenly tighten all screws to insure complete seal.

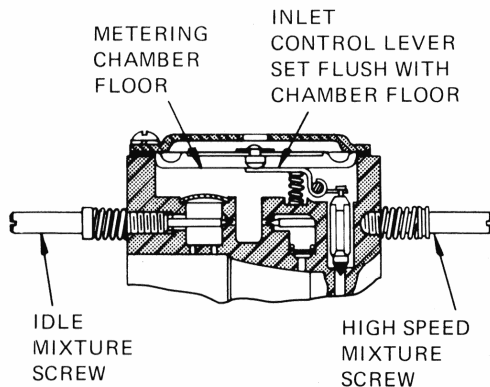

When reassembling the inlet control lever and spring, care should be taken to see that the spring rests in the well of the metering body and locates on the dimple of the inlet control lever (as illustrated above). CAUTION: Do not stretch spring. Inlet control lever is properly set when flush with the floor of the diaphragm chamber. If diaphragm end of control lever is low, pry up. If lever is high, depress diaphragm end and push on needle for proper adjustment. (See illustration). On some models the inlet control lever is hooked to the inlet needle at one end. Special care is required when reassembling these parts to insure proper operation.

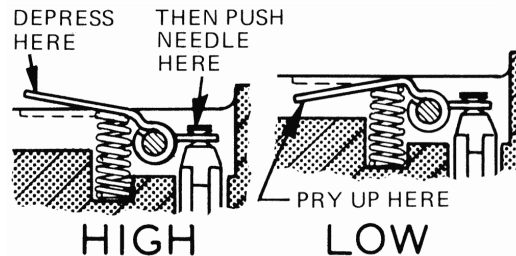

CAUTION:

Under extreme conditions of clogged idle fuel channel and discharge ports, it may be necessary to remove the channel welch plug. If so, it must be done very carefully in the following manner:

1. Drill a 1/8" diameter hole through the 9/32" diameter welch plug. This hole should just break through the welch plug. Deeper drilling will seriously damage the body casting and render the carburetor non-serviceable.
2. Carefully pry out the welch plug and clean discharge ports and cross channels. To re-install, place welch plug in well, convex side up, and flatten with a flat end tool slightly larger than the welch plug.
3. A nozzle brass cup plug can be removed in the same manner by using a 5/32" drill, or if you have a check ball cage this should be pressed out and a new one pressed in.

TROUBLE SHOOTING

Carburetor Floods

- | | |
|--|--|
| 1. Dirt or foreign particles preventing inlet needle from seating. | Remove, clean and replace. |
| 2. Diaphragm lever spring not seated on lever dimple. | Remove, lever and reinstall |
| 3. Diaphragm improperly installed in carburetor. | Replace diaphragm or correct installation. |

Engine Will Not Accelerate.

- | | |
|--|---|
| 1. Idle mixture too lean. | Readjust |
| 2. Incorrect setting on diaphragm lever. | Reset |
| 3. Diaphragm cover plate loose. | Tighten |
| 4. Diaphragm gasket leaking. | Replace |
| 5. Main fuel orifice plugged. | Remove diaphragm cover, diaphragm, diaphragm lever and high speed mixture screw. Clean out orifice by blowing through high speed mixture screw threaded hole. |

Engine Will Not Idle

- | | |
|---|--|
| 1. Incorrect idle adjustment. | Reset to best idle. |
| 2. Idle discharge ports or channels clogged. | Blow out with compressed air, or, if compressed air is not available, clean and flush with gasoline. |
| 3. Diaphragm lever set incorrectly. | Reset diaphragm lever so it is flush with the floor of the diaphragm chamber. |
| 4. Throttle shutter cocked in the throttle bore causing fast idle. | Reset |
| 5. Dirty nozzle check valve or outlet screen. | Clean or replace |
| 6. Welch plug covering the idle discharge ports does not seal. This causes the engine to idle with idle mixture screw shut off. | Replace welch plug, following instructions outlined in service hints. |

Engine Runs Out Lean

- | | |
|--|-------------------------------------|
| 1. Tank vent not operating correctly. | Clean, if possible, or replace |
| 2. Leak in fuel system from tank to pump | Tighten or replace fittings or line |
| 3. Ruptured fuel pump diaphragm. | Replace |
| 4. Main fuel orifice plugged. | Clean |

Carburetor Runs Rich with High Speed Mixture Screw Shut Off

- | | |
|--|------------------------------|
| 1. The 3/6" diameter nozzle cup plug, nozzle check valve cage, is not sealing. | Install new plug or new cage |
|--|------------------------------|

Set engine idling speed in accordance with engine manufacturer's recommendation.

TROUBLE SHOOTING

