



# Adjustment of the AFR Standard Screw

There are two primary methods of adjusting the TillotsonTCT fuel system. The first method is to adjust only the idle speed through the idle speed screw. This adjustment is done if engine is hunting or not running steady only at idle. The second is to adjust the air-fuel ratio through the AFR screw. This adjustment adjusts the amount of fuel being delivered from idle through wide-open throttle and is used if the engine is hunting or running abnormally at more than one speed or if the problem is not corrected through adjustment of the idle screw (possible causes include operation at altitudes greater than 400m (1312 ft) above sea level or a change in the grade of fuel used).

## 1. Adjusting the Idle Speed Screw.

If the engine is hunting or running improperly only at idle, you can adjust the amount of fuel being delivered at idle by turning the idle speed screw with an allen key. Turning the screw clockwise increases the idle speed. The gauge on the top of the TillotsonTCT shows how many degrees the throttle shutter is open. If adjusting the idle screw does not solve your problem, return it to the original position and adjust the AFR screw as shown in the next step. If the engine still does not operate properly, first open the idle screw a few degrees at a time, then adjust the AFR screw up to 1/2 turn.

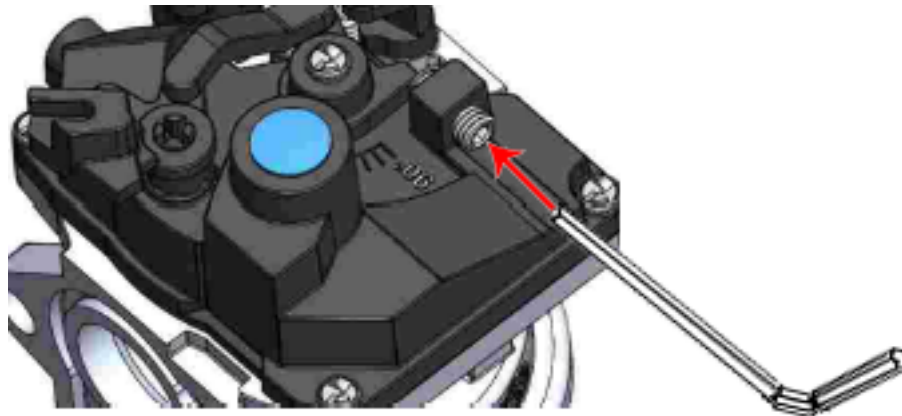

Figure 1.1

On Tillotson vertical engines, the idle speed screw is accessible through a hole in the air filter cover.

## 2. Adjusting the AFR Screw.

If the engine continues to hunt or run improperly at speeds other than idle, you can adjust the entire air-fuel mixture range by adjusting the AFR Screw.

On models without the EPA limiter screw, the adjustment is made with a 2.5mm allen key. For models with the EPA limiter screw, the adjustment is made with a flat head screw driver and is limited to +/- 1/2 turn. To adjust:

1. Remove the Cover Plug A (Figure 1.1)
2. Place the allen key into the well and into the head of the AFR screw (Figures 1.2 and 1.3)
3. Turn the AFR screw in 1/8 turn increments, counterclockwise to make the fuel mixture richer or clockwise to make the fuel mixture leaner (Figure 1.4). If the engine continues to run rich or lean after the initial adjustment, a further adjustment in 1/8 turn increments may be necessary.

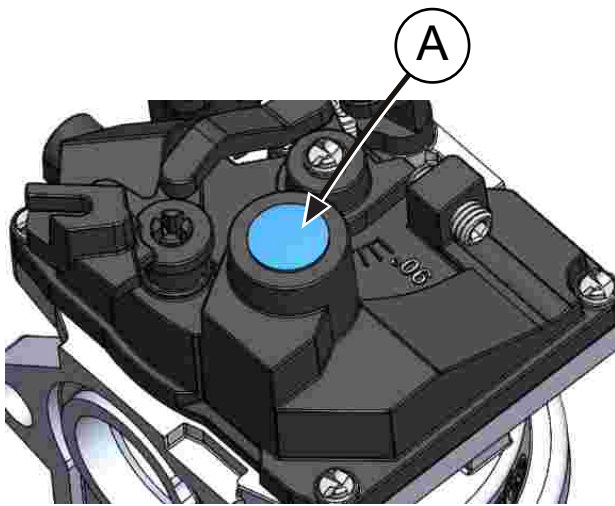

Figure 1.1

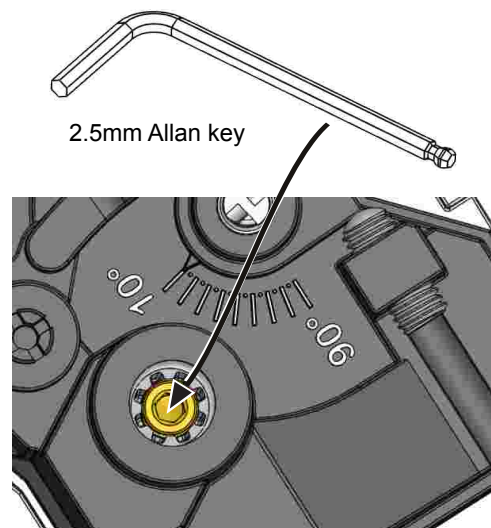

Figure 1.2

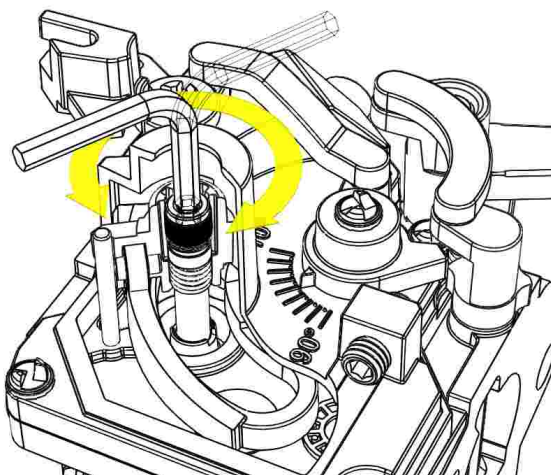

Figure 1.3

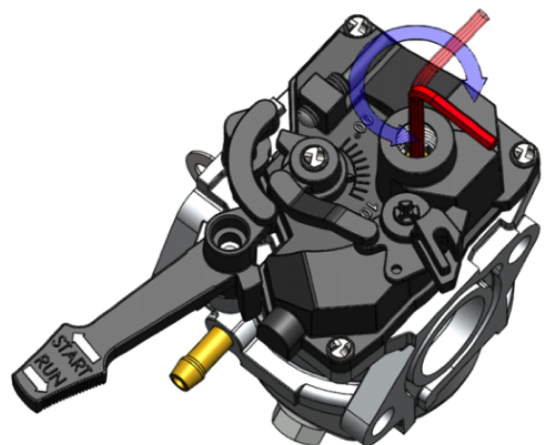

Figure 1.4



# Technical Data

**How the AFR Adjustment works:** The AFR screw adjusts the needle height relative to the cam position.

- B) AFR screw
- C) Fuel needle
- D) Cam Follower
- E) Cam

Raising the needle richens the mixture (increases the fuel) while lowering the needle leans the mixture (reduces the fuel).

For most 160-208cc engines, normal adjustment parameters is +/- 1/2 turn from standard.

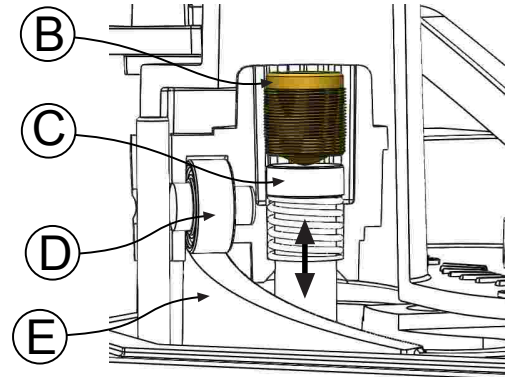
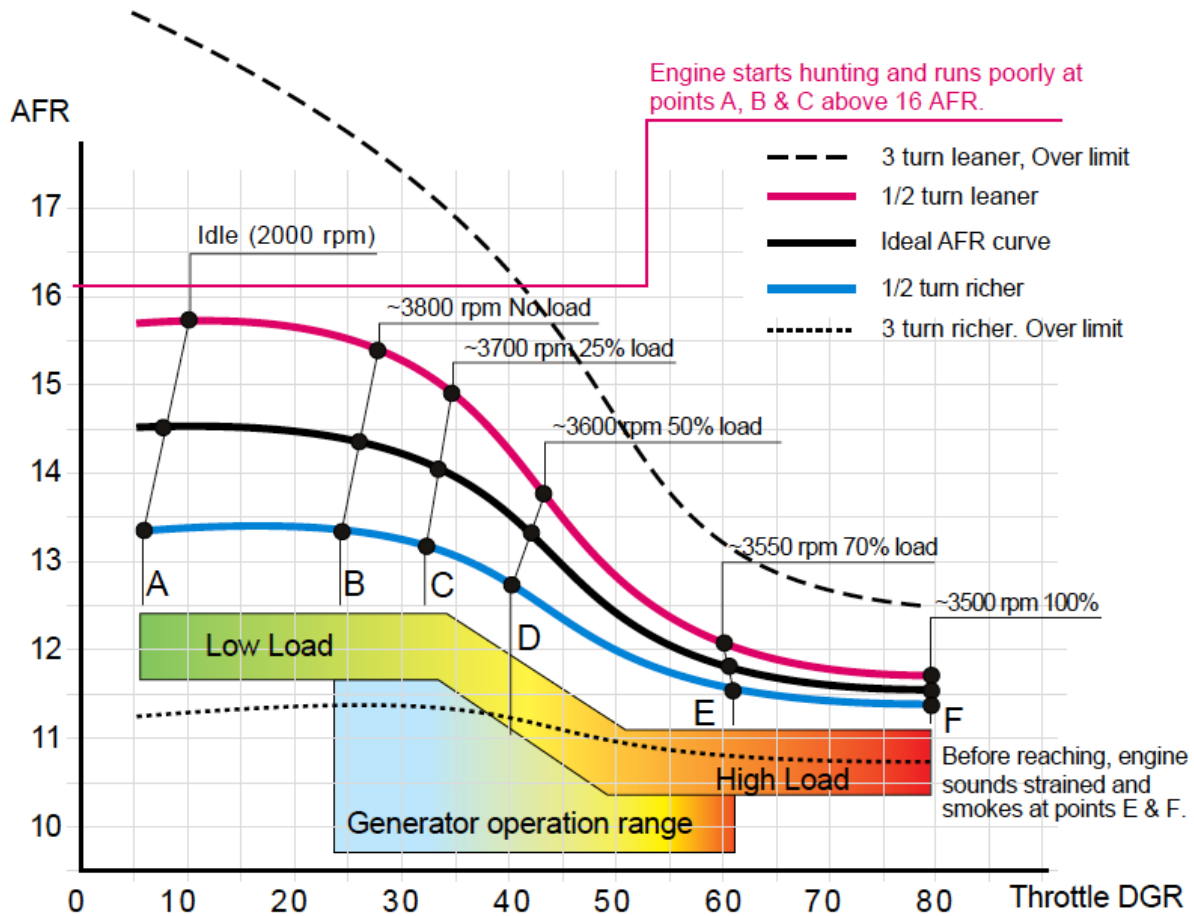

Figure 2.2

**Full Adjustability:** The TillotsonTCT technology also permits the engine to meet emissions at all points of adjustment within normal operating parameters (that is, prior to substantial degradation in engine performance ).



\* The Black line indicates the ideal AFR curve, where we set the engine to operate to minimize emission and maximize performance and fuel economy. The AFR is approximately 14.5 at idle and the H+NOx emissions are 6.5 to 7.5 g/kWh.

\* The Red and Blue lines indicate the normal adjustment parameters, +/- 1/2 turn. Engine performance begins to degrade beyond that range. The engine is still well within emissions parameters, with H+NOx emissions at about 8.5-9 g/kWh.

\* The black dotted and dashed lines indicate where the engine begins to violate emissions. Before reaching the black dashed line, the engine is running too lean and hunting. Before reaching the black dotted line, the engine sounds bad and is smoking under load.

\* CO emissions are within guidelines at all curves.